



SUZUKI

GS 550



Electrical Diagrams

Model GS 550 B

Year: 1977

Frame: 100374

Rewired 2006

Left switch handlebar is a 1980 GS550E

Fuse box and permanent headlight added

Fuse Box

GROUND			
5A	6		
16A	5		
10A	4		
5A	3		
16A	2		
16A	1		

Fuse		W	A
1	Charge	200	16
2	Main	200	16
3	Rearlight	5	
	Brakelight	20	
	Total	25	5
4	Starterelay	5	
	Ignition	96	
	Total	101	10
5	Turn front	10	
	Turn Back	10	
	Turn indicator	3	
	Headlight Hi	60	
	Headlight Lo	55	
	Hi-Beam indicator	3	
	Horn	10	
	Total	151	16
6	Backgroundlight	12	
	Oilpressure	3	
	Neutral indicator	3	
	Gearpos. Indicators	1	
	Total	19	5

Relay Cluster

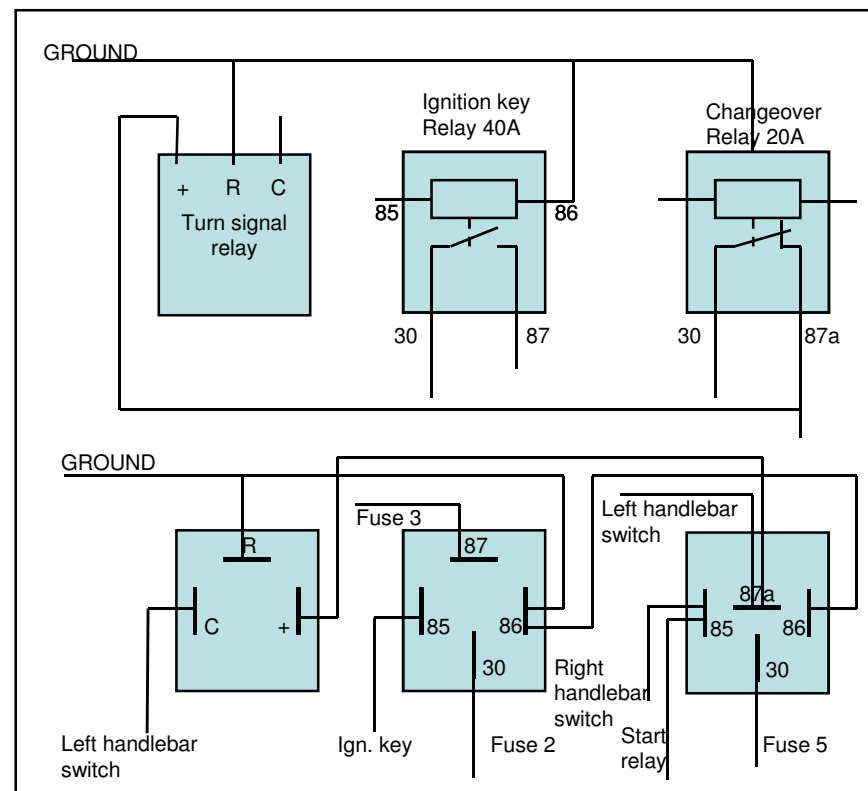

Wire Colours

B	Black
Bl	Blue
Br	Brown
G	Green
Gr	Gray
Lbl	Light Blue
Lg	Light Green
O	Orange
R	Red
W	White
Y	Yellow
B/W	Black with White tracer
x/y	X with Y tracer



GS 550	Year: 1977
Legend & Terminals	100374

1	Left Turn signal	Head light
2	Right Turn signal	Housing
3	Ground	Terminal
4	Ground	Block
5	Headlight Lo-Beam	
6	Headlight Hi-Beam	
7	Front brake switch 12V	
8	Front brake switch signal	
9	Ignition key 12V	
10	Ignition key 12V switched	

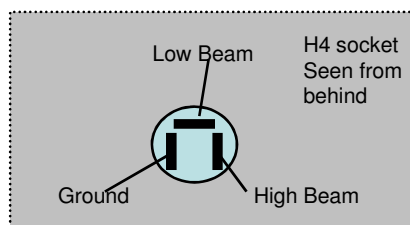



Sikringsboks
Biltema 35-095



Tilkoblingsrelæ
Biltema 42-302



Sikringer
Biltema 35-460

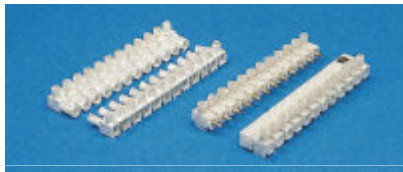

Klemrække (Elkay)
RS-Components 424-579

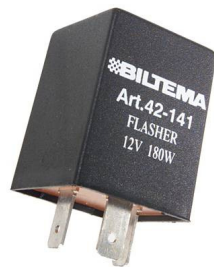

Blinkrelæ
Biltema 42-143

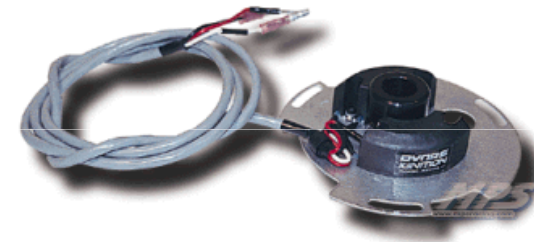

DYNA-S DS3-1



3 stk relæsokkel (Bosch)
RS-Components 134-9479

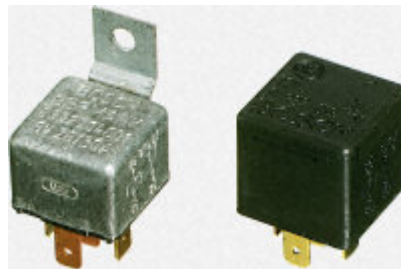

Skifterelæ (Bosch)
RS-Components 134-9356

Texts in Danish like order text.



GS 550	Year: 1977
Components	100374

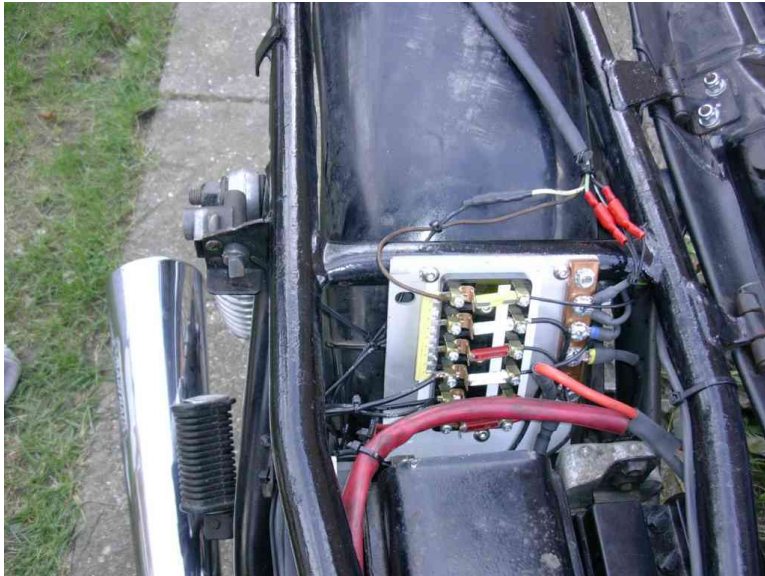

Fusebox – placed below seat

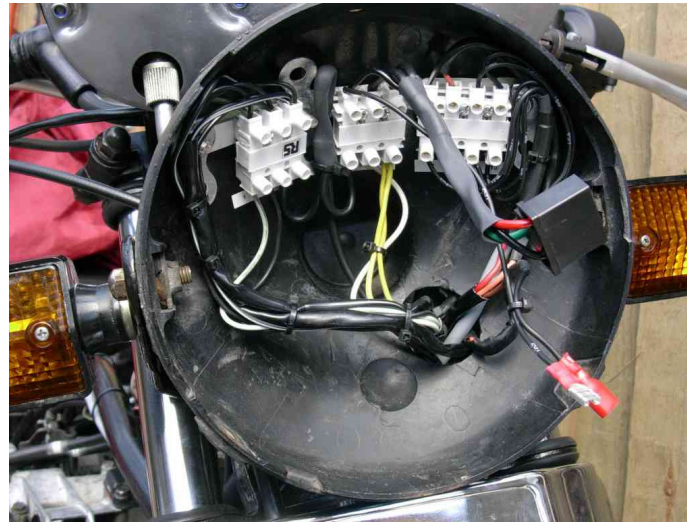
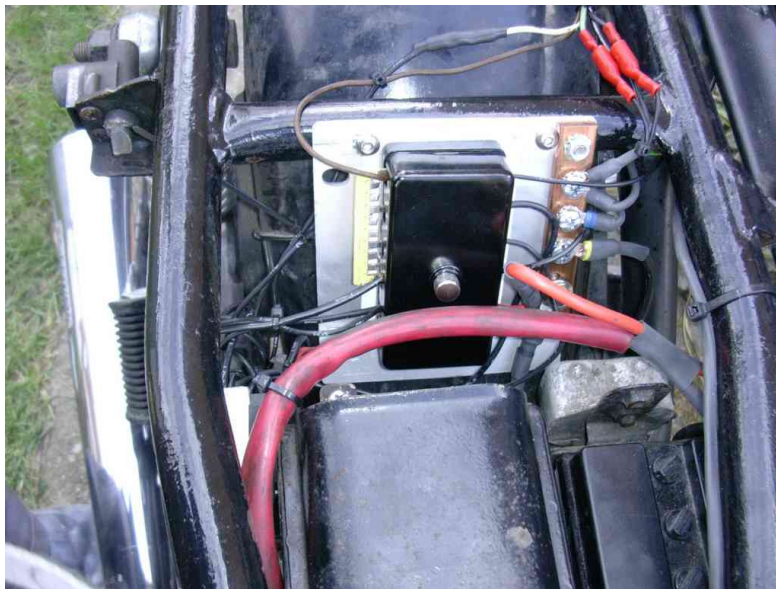

Connectionpoint – placed inside headlighth

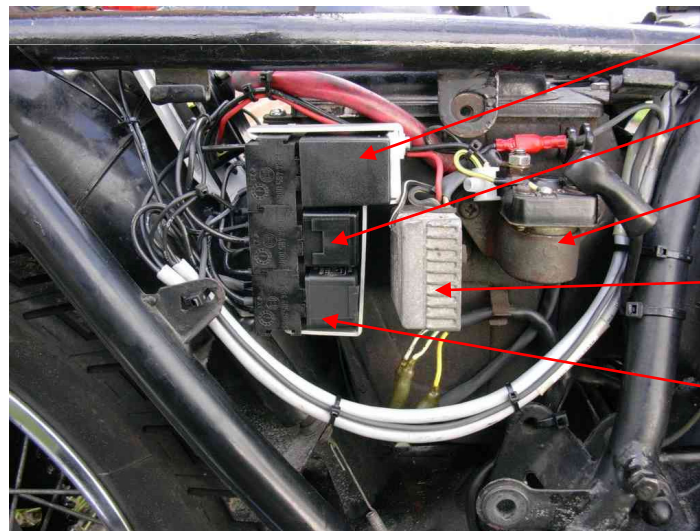

Turn signal relay

Main relay

Start relay

Rectifier

Light switchover

Relay cluster – placed under right side shield



GS 550	Year: 1977
Pictures	100374

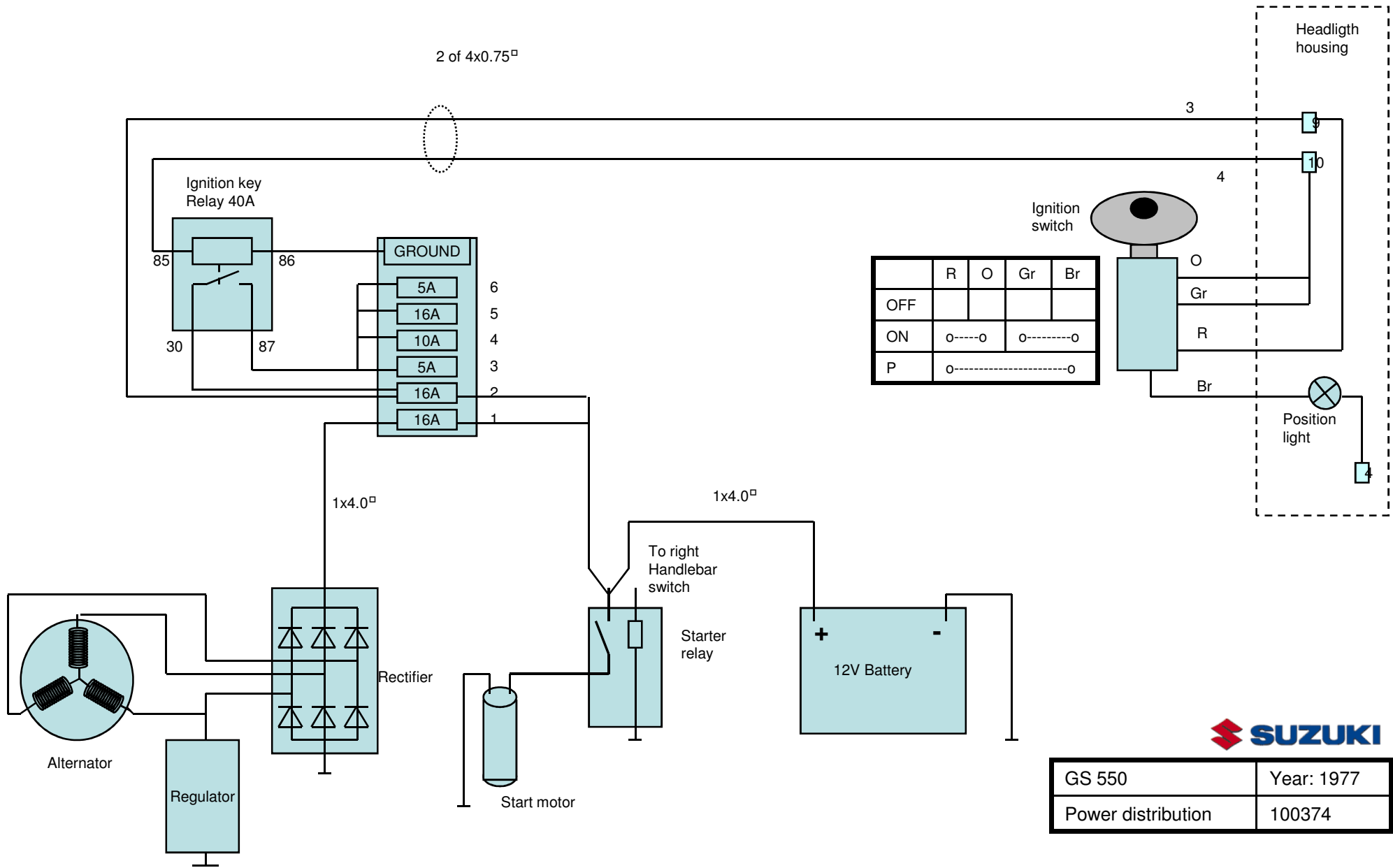

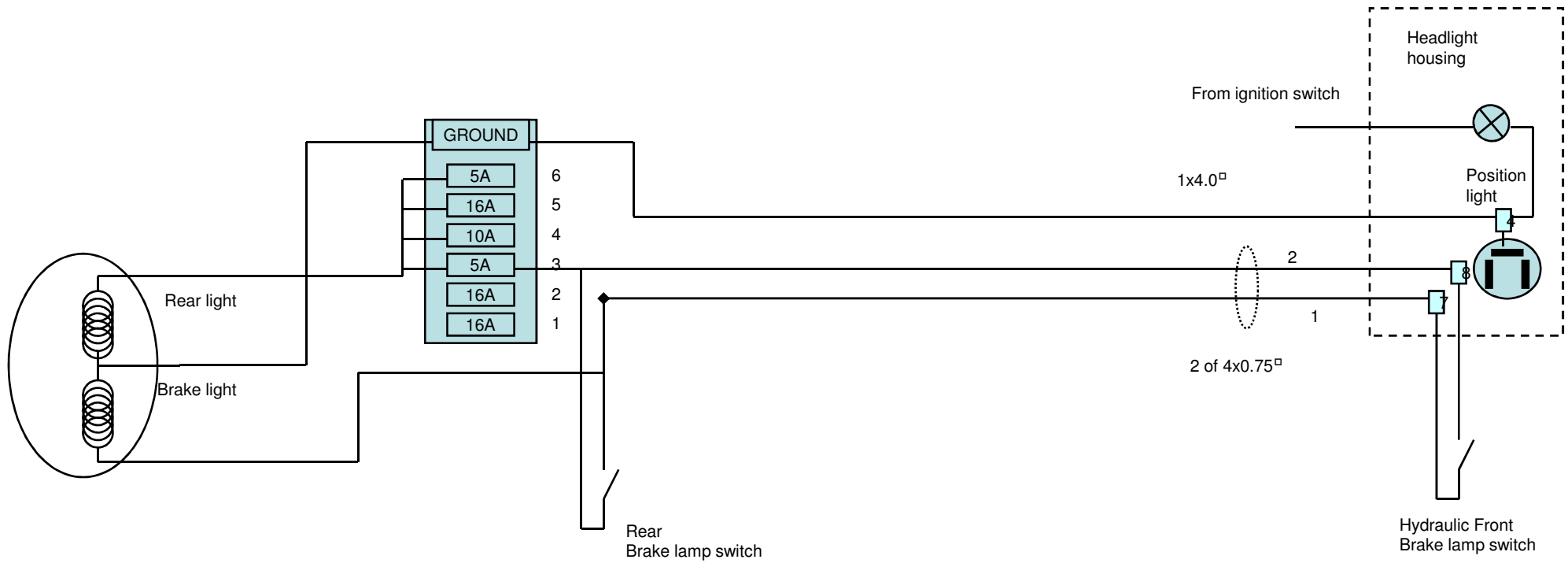

GS 550	Year: 1977
Brake light	100374

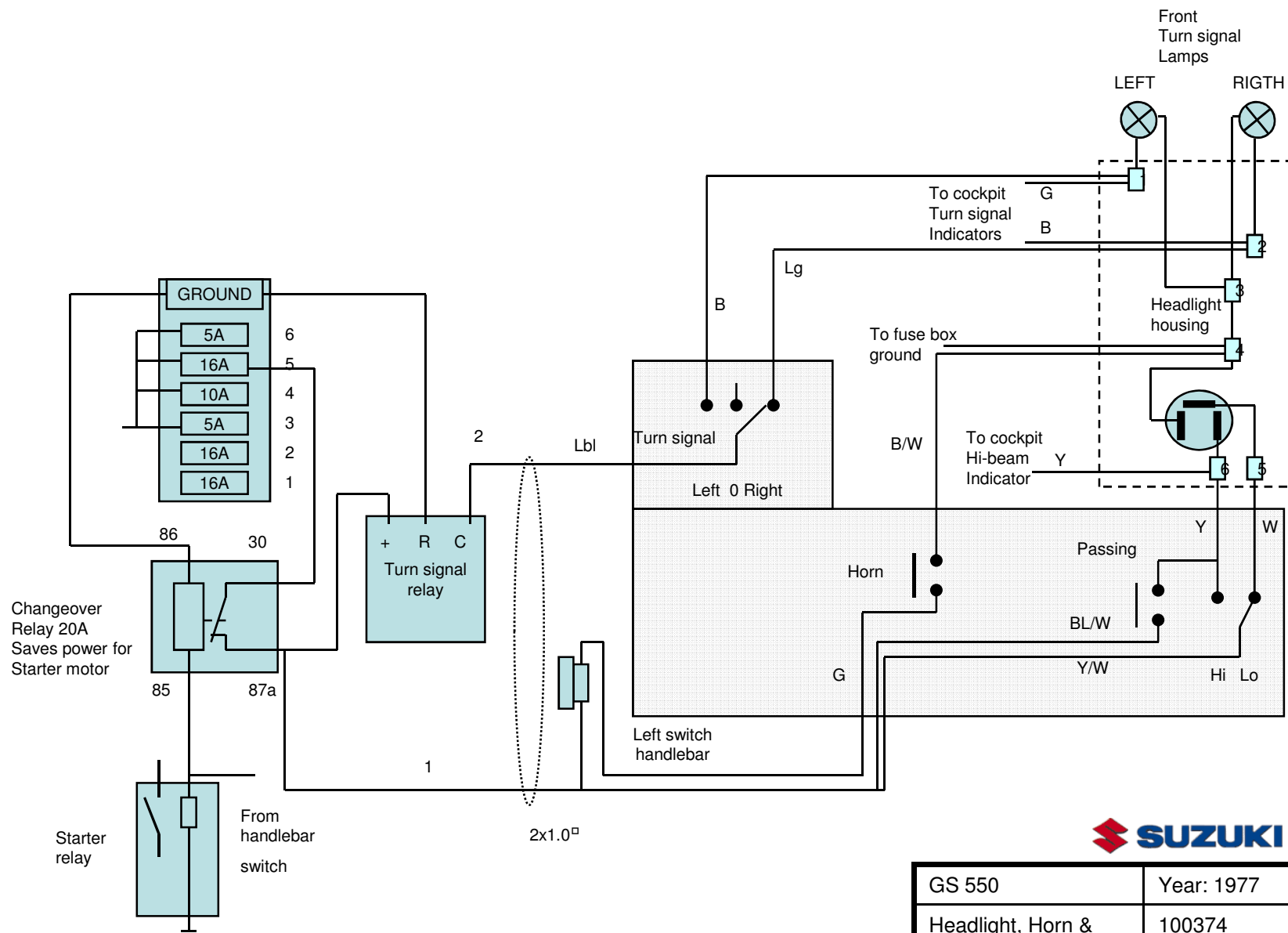

GS 550	Year: 1977
Headlight, Horn & Turn signal front	100374

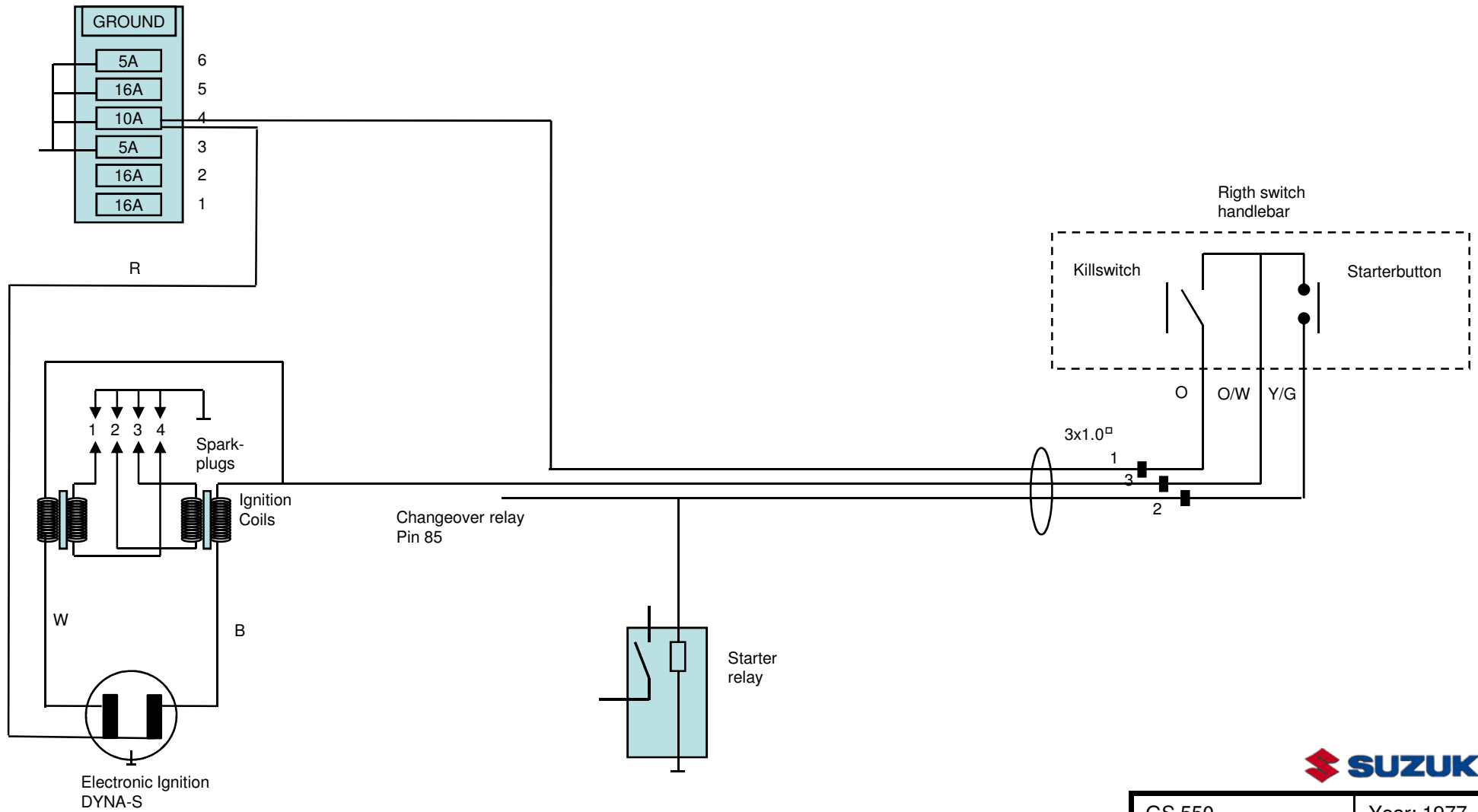

GS 550	Year: 1977
Start & Ignition	100374

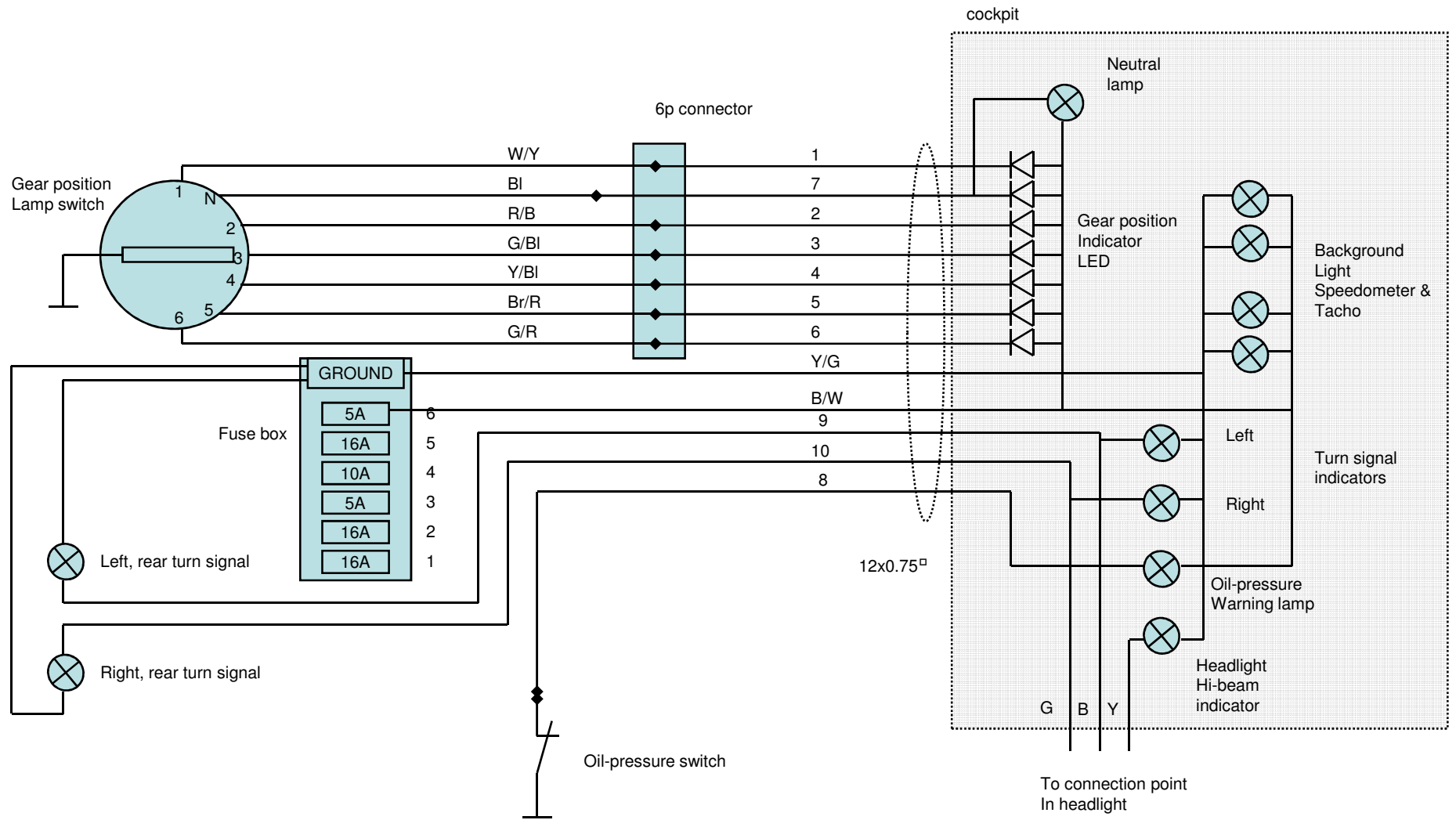

GS 550	Year: 1977
Gear indicator + cockpit	100374